

Needle, Toggle & Metering Valves

The best partner for value creation
We support the innovations of customers



13



Catalogue No. S-LOK Oct.2020

SNV50 Series Integral Bonnet Needle Valves

✦ Features

- Pressure rating up to 5000psig (344bar) at 21 °C (70 °F).
- Temperature rating from -54 °C (-65 °F) to 232 °C (450 °F) with standard PTFE packing and up to 315 °C (600 °F) with optional PEEK packing.
- Choice of material : Standard SS316 and available in Alloy 400 & Brass.
- Available Sour Gas service per NACE MR0175.
- Applications : General Purpose Gas, Water and Oil
- Variety stem tips include Vee, Regulating and Soft-Seat with PCTFE (KEL-F).
- Forged body with straight and angle patterns.
- Stem threads are hard chrome-plated for maximum service life.
- Packing nut enables easy external adjustments to ensure leak-free stem seal.
- Variety of end connections include reliable S-LOK tube fittings, male/female NPT & ISO threads.



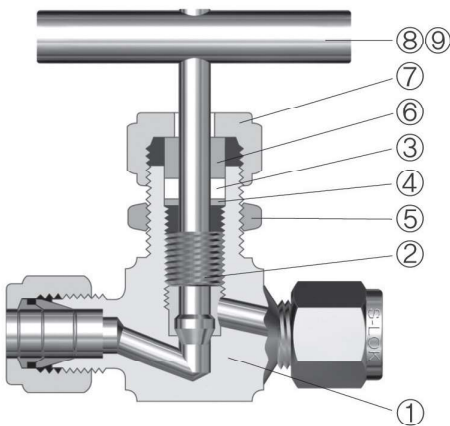

✦ Materials of Construction



No	Component	Material		
		Stainless Steel	Brass	Alloy 400
1	Body	SS316/ A182	Brass / B124	Alloy 400 / B564
2	Vee	Chrome Plate SS316 / A479 or A276	SS316 / A479 or A276	Alloy R-405 / B164
	Soft Seat			
	Regulating			
2a	Stem Tip	PCTFE (KEL-F)		
3	Packing	PTFE (Optional PEEK)		
4	Packing Ring	SS316 / A479 or A276	Brass / B16	Alloy R-405 / B164
5	Panel Nut			
6	Gland			
7	Packing Nut	SS316 / A276		
8	Knob Handle	Black Phenolic Knob (Standard)		
	Bar Handle	SS316 / A276		
9	Set Screw	Stainless Steel		

✦ Technical Data

Choice of Stem Tip's Available

Vee Stem	Regulating Stem	Soft Seat Stem
For pressure tightness even at elevated temperatures	For flow rate control	For repetitive shut-off
		

Pressure-Temperature Rating with Packing and Body Material

Valve Material	Stem	PTFE Packing (Standard)		PEEK Packing (Optional)	
		Temperature Range °C (°F)	Pressure Rating @38°C(100°F)	Temperature Range °C (°F)	Pressure Rating @Max. Temp.
Stainless Steel 316	Vee & Regulating Stem (Metal Seat)	-54°C to 232°C (-65°F to 450°F)	5000psig (344 bar)	-54°C to 315°C (-65°F to 600°F)	3130psig (215 bar)
	Soft Stem (PCTFE Seat)	-54°C to 93°C (-65°F to 200°F)		-54°C to 93°C (-65°F to 200°F)	4295psig (295 bar)
Brass	Vee & Regulating Stem (Metal Seat)	-54°C to 204°C (-65°F to 400°F)	3000psig (206 bar)	-54°C to 204°C (-65°F to 400°F)	390psig (26 bar)
	Soft Stem (PCTFE Seat)	-54°C to 93°C (-65°F to 200°F)		-54°C to 93°C (-65°F to 200°F)	2350psig (161 bar)
Alloy 400	Vee & Regulating Stem (Metal Seat)	-54°C to 232°C (-65°F to 450°F)	3000psig (206 bar)	-54°C to 260°C (-65°F to 500°F)	2375psig (163 bar)
	Soft Stem (PCTFE Seat)	-54°C to 93°C (-65°F to 200°F)		-54°C to 93°C (-65°F to 200°F)	2460psig (181 bar)

Temperature-Working Pressure

- The class rating and rated working pressure are the way that ASME standards simplify the design process.
- The pressure rating is governed by the allowable stress for each different material group, class rating and service temperature.

ASME Material Group	Table 2-2.2	N/A	Table 2-3.4
ASME Class Rating	2080	N/A	1500
Material Name	Stainless Steel 316	Brass	Alloy 400
Temperature, °C (°F)	Working Pressure, psig (bar)		
-54°C (-65°F) to 38°C (100°F)	5000 (344)	3000 (206)	3000 (206)
93°C (200°F)	4295 (295)	2350 (161)	2630 (181)
148°C (300°F)	3875 (266)	2050 (141)	2450 (168)
204°C (400°F)	3560 (245)	390 (26)	2365 (163)
260°C (500°F)	3310 (228)	-	2365 (163)
315°C (600°F)	3130 (215)	-	-

- Pressure ratings of valves with S-LOK end connections are determined by the tubing material and wall thickness.
- Pressure rating of valve is sometimes limited to the working pressure of pipe ends and the tubing connected.

Flow Coefficient (Cv) with Number of Handle Turns

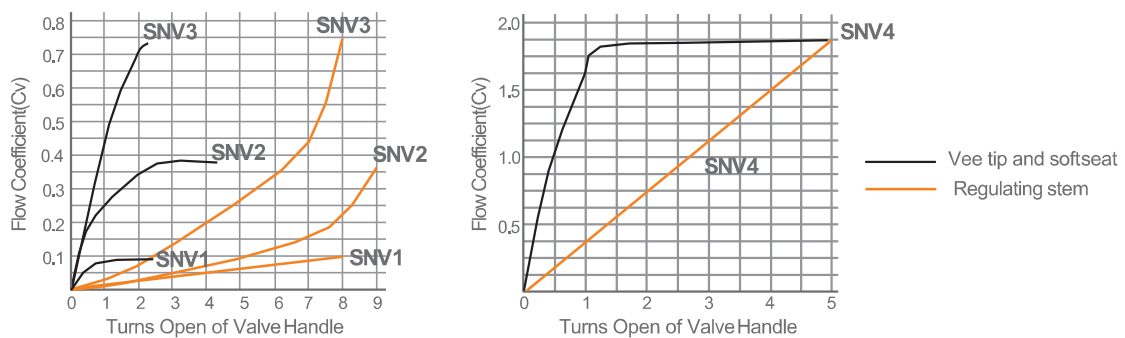

Testing

- Every valve is factory tested with Nitrogen @ 1000psig (69bar)
- Seats have a maximum allowable leak of 0.1 (SSCM).
- Hydrostatic shell tests is performed optional with water at 1.5 times the working pressure.

Ordering Information & Dimensions

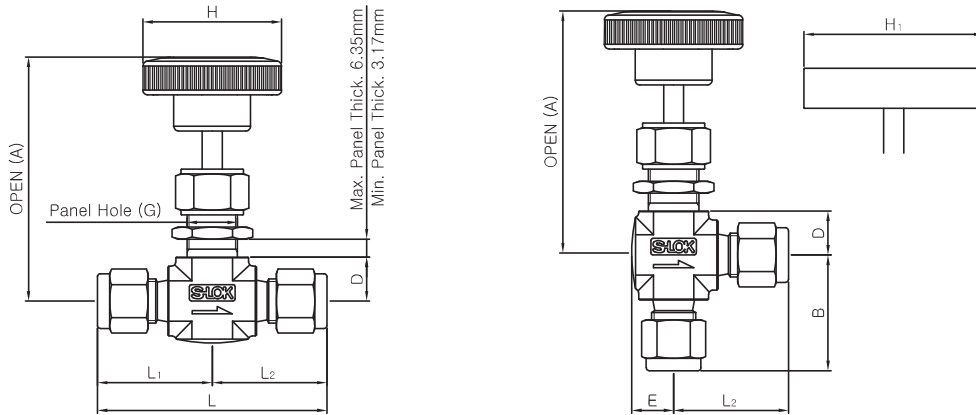

Ordering Number	Orifice (mm)	Cv	End Connections		Dimensions (mm)										
			Inlet	Outlet	A	B	L	L ₁	L ₂	E	D	H	H ₁	G	
SNV1	F-2N	2.0	0.09	1/8" Female NPT		61.0	21.0	42.0	21.0		9.5	11.0	35.0	32.0	13.5
	M-2N			1/8" Male NPT					26.0	26.0					
	MS-2N2T			1/8" Male NPT	1/8" S-LOK			52.0							
	S-2T			1/8" S-LOK											
	S-3M			3mm S-LOK											
SNV2	F-2N	4.4	0.37	1/8" Female NPT		61.0	21.0	42.0	21.0		9.5	11.0	35.0	45.0	13.5
	M-2N			1/8" Male NPT					25.0	25.0					
	M-4N			1/4" Male NPT				54.0							
	MS-4N4T			1/4" Male NPT	1/4" S-LOK										
	S-6M			6mm S-LOK											
	S-4T			1/4" S-LOK				29.0	29.6						
	S-8M			8mm S-LOK											
SNV3	F-4N	6.4	0.73	1/4" Female NPT		77.0	28.0	56.0	28.0		13.0	13.5	47.0	64.0	19.8
	F-4R			1/4" Female ISO Thread					61.2	33.2					
	MF-4N			1/4" Male NPT	1/4" Female NPT			29.0							
	MS-4N6T			1/4" S-LOK	3/8" S-LOK										
	M-6N			3/8" Male NPT											
	MS-6N6T			3/8" Male NPT	3/8" S-LOK			62.2	36.0						
	MS-6N8T			3/8" Male NPT	1/2" S-LOK										
	S-10M			10mm S-LOK				33.0	33.2						
	S-6T			3/8" S-LOK											
	S-12M			12mm S-LOK				36.0	36.0						
	S-8T			1/2" S-LOK											
	SNV4			F-6N	9.5			1.80	3/8" Female NPT						
F-6R		3/8" Female PT													
F-8N		1/2" Female NPT													
F-8R		1/2" Female ISO Thread													
M-8N		1/2" Male NPT													
MF-8N		1/2" Male NPT	1/2" Female NPT	49.0		48.5									
S-8T		1/2" S-LOK													
S-12T		3/4" S-LOK													

* Dimensions are for reference only and are subject to change.

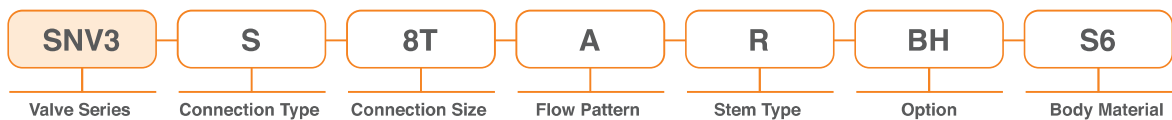

- Nil : Straight
- A : Angle Pattern
- Nil : Vee Stem
- R : Regulating Stem
- K : Soft Seat Stem
- Nil : Standard
- BH : Bar Handle
- PK : PEEK Packing
- SG : Sour Gas Service
- S6 : 316 Stainless Steel
- BS : Brass
- A400 : Alloy 400

SBNV60 Series

Integral Bonnet Bar Stock Needle Valves

Features

- Pressure rating up to 6000psig (413bar) at 21°C (70°F).
- Temperature rating from -54°C (-65°F) to 232°C (450°F) with standard PTFE packing and up to 315°C (600°F) with optional PEEK packing.
- Choice of material : Standard SS316 and available in Alloy 400 & Brass.
- Available Sour Gas service per NACE MR0175
- Applications : General Purpose Gas, Water and Oil
- Variety stem tips include Vee, Regulating and Soft-Seat with PCTFE (KEL-F).
- Bar stock body with straight and angle patterns.
- Stem threads are hard chrome-plated for maximum service life.
- Packing nut enables easy external adjustments to ensure leak-free stem seal.
- Variety of end connections include reliable S-LOK tube fittings, male/female NPT & ISO threads.



Materials of Construction

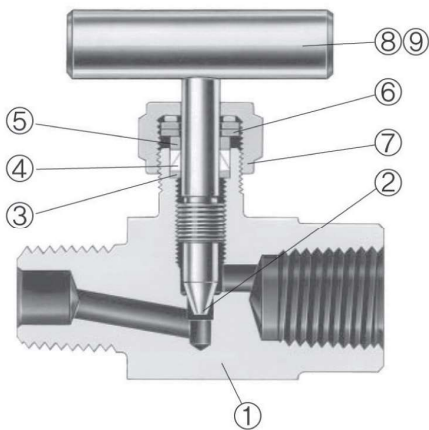

No	Component	Material	
		Stainless Steel	Alloy 400
1	Body	SS316 / A479 or A276	Alloy 400 / B564
2	Vee	Chrome Plate SS316 / A479 or A276	Alloy R-405 / B164
	Soft Seat		
2a	Stem Tip	PCTFE (KEL-F)	
3	Packing	PTFE (Optional PEEK)	
4	Packing Ring	SS316 / A479 or A276	Alloy R-405 / B164
5	Panel Nut	SS316 / A479 or A276	Alloy R-405 / B164
6	Packing Spring	17-7PH	
7	Packing Nut	SS316 / A276	
8	Bar Handle	SS316 / A276 (Standard)	
9	Set Screw	Stainless Steel	

Technical Data

Pressure-Temperature Rating with Packing and Body Material

Valve Material	Stem	PTFE Packing (Standard)		PEEK Packing (Optional)	
		Temperature Range °C (°F)	Pressure Rating @38°C(100°F)	Temperature Range °C (°F)	Pressure Rating @Max. Temp.
Stainless Steel 316	Vee Stem (Metal Seat)	-54°C to 232°C (-65°F to 450°F)	6000psig (413 bar)	-54°C to 315°C (-65°F to 600°F)	3760psig (259 bar)
	Soft Stem (PCTFE Seat)	-54°C to 93°C (-65°F to 200°F)		-54°C to 93°C (-65°F to 200°F)	5160psig (355bar)
Alloy 400	Vee Stem (Metal Seat)	-54°C to 232°C (-65°F to 450°F)	5000psig (344 bar)	-54°C to 260°C (-65°F to 500°F)	3940psig (271 bar)
	Soft Stem (PCTFE Seat)	-54°C to 93°C (-65°F to 200°F)		-54°C to 93°C (-65°F to 200°F)	4380psig (301bar)

* Not applicable over 260°C(500°F) PEEK is not recommended for service with aromatic heat transfer fluids or concentrated sulfuric and nitric acids. Other limitations may apply.

Temperature-Working Pressure

ASME Material Group	Table 2-2.2	Table 2-3.4
ASME Class Rating	2500	
Material Name	Stainless Steel 316	Alloy 400
Temperature, °C (°F)	Working Pressure, psig (bar)	
-54°C (-65°F) to 38°C (100°F)	6000 (413)	5000 (344)
93°C (200°F)	5160 (355)	4380 (301)
148°C (300°F)	4660 (321)	4080 (281)
204°C (400°F)	4280 (295)	3940 (271)
260°C (500°F)	3980 (274)	3940 (271)
315°C (600°F)	3760 (259)	3940 (271)

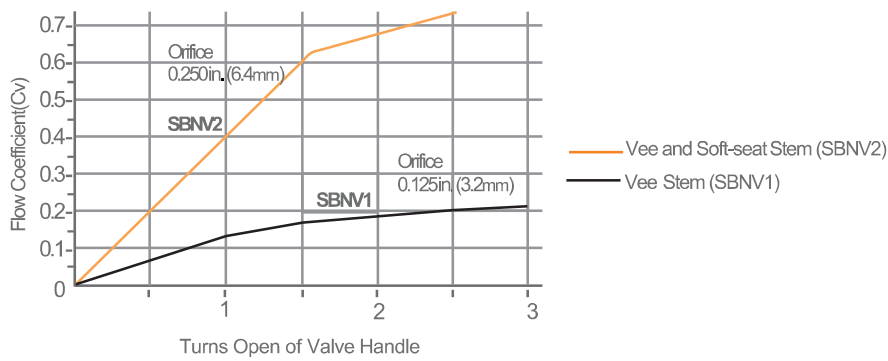

- Pressure ratings of valves with S-LOK end connections are determined by the tubing material and wall thickness.
- For more information about pressure ratings of valves with tube fitting end connections.
- Pressure rating of valve is sometimes limited to the working pressure of pipe ends and the tubing connected.

Flow Coefficient (Cv) with Number of Handle Turns



Choice of Stem Tip's & Handle Available

- Stainless steel bar handle is standard all valves.
- Black phenolic knob is standard for soft seat stem valves

Vee Stem	Regulating Stem	Soft Seat Stem
For pressure tightness even at elevated temperatures	For flow rate control	For repetitive shut-off
		

Testing

- Every valve is factory tested with Nitrogen @ 1000psig (69bar)
- Seats have a maximum allowable leak of 0.1 (SSCM).
- Hydrostatic shell tests is performed optional with water at 1.5 times the working pressure.

Ordering Information & Dimensions

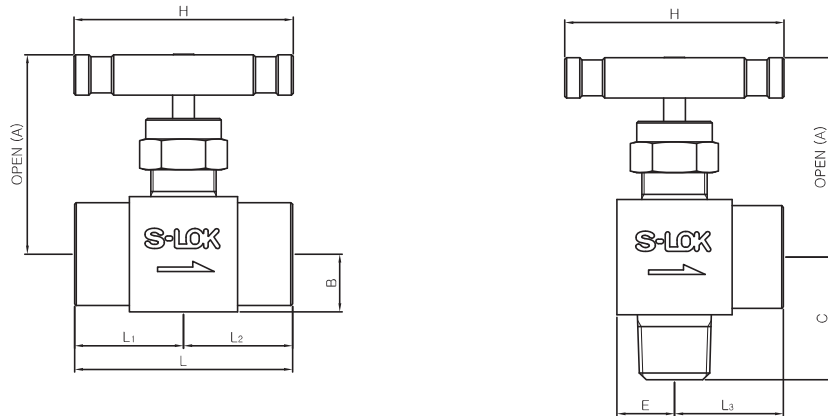

Ordering Number	Orifice (mm)	Cv	End Connections		Dimensions (mm)									
			Inlet	Outlet	A	B	C	L	L ₁	L ₂	L ₃	E	H	
SBNV1	F-4N	3.2	0.21	1/4" Female NPT		42.2	11.2	25.4	47.8	23.9		25.4	11.2	44.5
	F-4R			1/4" Female ISO Thread				-	49.2	24.6		-		
	M-4N			1/4" Male NPT				26.2	48.5	24.6	23.9	26.2		
	MF-4N			1/4" Male NPT	1/4" Female NPT									
	MS-4N4T			1/4" Male NPT	1/4" S-LOK			29.5	62.5	31.2		29.5		
	S-4T			1/4" S-LOK										
SBNV2	F-6N	6.4	0.73	3/8" Female NPT		58.7	16.8	31.8	63.5	31.8		16.8	64.0	
	F-8N			1/2" Female NPT				35.8		31.8				
	F-8R			1/2" Female ISO Thread				31.0		31.8				
	MF-6N			3/8" Male NPT	3/8" Female NPT			35.8	64.8	33.0	31.8			31.8
	MF-8N			1/2" Male NPT	1/2" Female NPT									
	MF-12N8N			3/4" Male NPT	1/2" Female NPT			-	63.5	31.8				-
	S-6T			3/8" S-LOK				-	78.2	39.1				-
	S-8T			1/2" S-LOK				-	83.8	41.9				-

* Dimensions are for reference only and are subject to change.

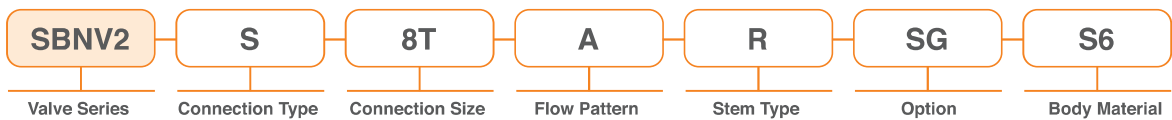

- Nil : Straight
- A : Angle Pattern
- Nil : Vee Stem
- R : Regulating Stem
- Nil : Standard
- Nil : PEEK Packing
- S6 : 316 Stainless Steel
- A400 : Alloy 400
- K : Soft Seat Stem
- SG : Sour Gas Service

SHNV100 Series High Pressure Needle Valves

↗ Features

- Pressure rating up to 10000psig (689bar) at 21 °C (70°F).
- Temperature rating from -54 °C (-65 °F) to 232 °C (450 °F) with standard PTFE packing and up to 648 °C (1200 °F) with optional Graphite packing.
- Chevron PTFE packing design provides highly qualified sealing maintain ability.
- Packing Bolt allows external packing adjustment.
- Packing under the stem threads is to isolate threads from system fluid and lubricant washout.
- Non-rotating stem tip at closure is used for long-life and leak-tight shutoff.
- Lock plate ensures the valve to be fastened to the body.
- Available Sour Gas service per NACE MR0175.



↗ Materials of Construction

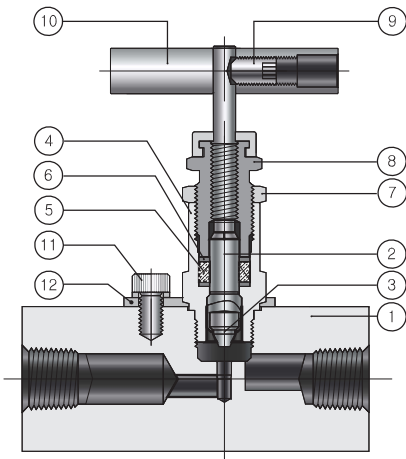

No	Component	Material	
		Stainless Steel	Carbon Steel
1	Body	SS316 / A479 or A276	JIS G4051
2	Stem	SS316 / A479 or A276	
3	Stem Tip	SS630 / A564 (17-4PH)	
4	Bonnet	SS316 / A479 or A276	JIS G4051
5	Packing	Chevron PTFE (Optional PEEK)	
6	Packing Ring	Reinforced PTFE	
7	Lock Nut	SS316 / A276	
8	Packing Bolt	SS316 / A479 or A276	JIS G4051
9	Set Screw	Stainless Steel	
10	Bar Handle	Stainless Steel	
11	Lock Bolt	Stainless Steel	
12	Lock Plate	Stainless Steel	

* Carbon Steel finished White zinc galvanized.

↗ Technical Data

Pressure-Temperature Rating with Packing and Body Material

Valve Material	Packing Material	Temperature Range °C (°F)	Pressure Rating @38 °C(100 °F)	Pressure Rating @Max. Temp.
Stainless Steel 316	PTFE	-54 °C to 232 °C (-65 °F to 450 °F)	10000psig (689 bar)	4130psig (285 bar)
	Graphite	-54 °C to 648 °C (-65 °F to 1200 °F)		1715psig (118bar)
Carbon Steel	PTFE	-29 °C to 176 °C (-20 °F to 350 °F)	10000psig (689 bar)	5230psig (360 bar)
	Graphite	-29 °C to 176 °C (-20 °F to 350 °F)		

Packing Adjustment and Actuation Torque

- Extreme or rapid temperature cycle while valve in service may require packing adjustment.
- Valves that have not been actuated for a period of time may have a higher initial actuation torque.

Testing

- Every valve is factory tested with Nitrogen @ 1000psig (69bar)
- Seats have a maximum allowable leak of 0.1 (SSCM).
- Stem packing is tested for the detection of no leakage.

Ordering Information & Dimensions

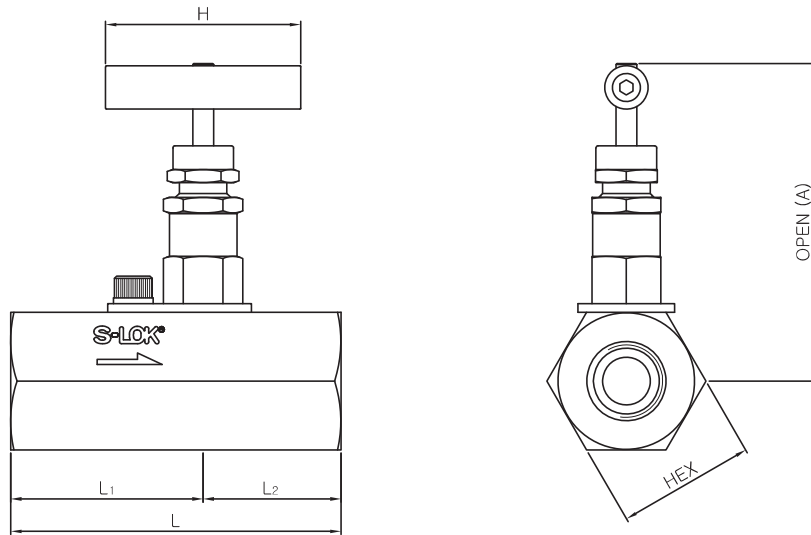

Ordering Number	Orifice (mm)	End Connections		Dimensions (mm)						
		Inlet	Outlet	A	L	L ₁	L ₂	HEX	H	
SHNV1	F-4N	3.2	1/4" Female NPT		72.7	76.2	44.4	31.8	31.8	45.0
	F-6N		3/8" Female NPT							
SHNV2	F-8N	5.0	1/2" Female NPT		94.8	76.2	38.1	38.1	38.1	64.0
	MF-8N		1/2" Male NPT	1/2" Female NPT						
	MF-12N		3/4" Male NPT	3/4" Female NPT	98.2	95.2	57.1	44.5		

* Dimensions are for reference only and are subject to change.

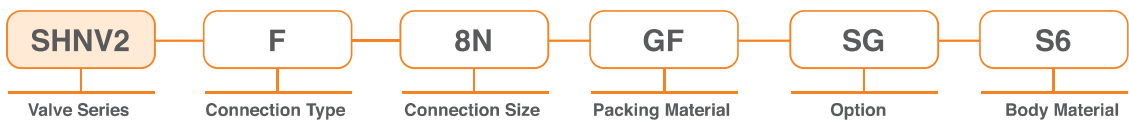

- Nil : PTFE (Standard)
- Nil : Standard
- GF : Graphite Packing
- SG : Sour Gas Service
- S6 : 316 Stainless Steel
- CS : Carbon Steel

SUNV60 Series Union Bonnet Needle Valves

↗ Features

- Pressure rating up to 6000psig (413bar) at 21°C (70°F).
- Temperature rating from -54°C (-65°F) to 232°C (450°F) with standard PTFE packing and up to 648°C (1200°F) with optional Graphite packing.
- Standard 316 Stainless Steel, optional Alloy 20 and Alloy C276 construction.
- Valve stem back seating against the bevelled edge of bonnet in fully open position prevents maximum leakage through bonnet when packing fails.
- Standard non-rotating stem tip and stem packing below the threads design.
- Available Sour Gas service per NACE MR0175.
- **Handle** standard 316 Stainless Steel bar handle.
- **External Packing Bolt** allow packing adjustment without disassembling the valve.
- **Roll threaded and hard chrome plated stem** is for extended valve's lifespan.
- **Panel Mounting Nut** is standard and permits the access of the valve panel or actuator.
- **Union Nut** prevents accidental disassembly of the valve in its service.
- **Stem packing below the threads** prevents media contamination and thread lubricant washout.
- **Non rotating stem tip at closure** is to maximize the lifespan of the metal seat and complete sealing.



↗ Material of Construction

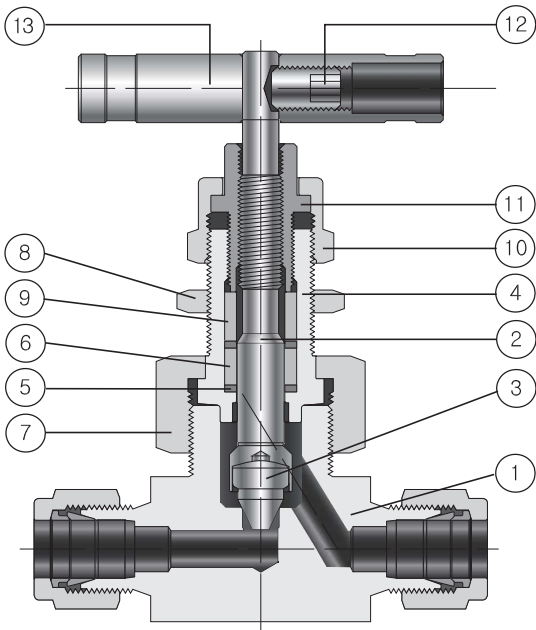

Note: *marked are wetted parts

No	Component	Material	
		Stainless Steel	Alloy C-276
1	Body	SS316 / A479 or A276	Alloy C-276
2	Stem	SS316 / A479 or A276	Alloy C-276
3	*Stem Tip	SS630 / A564 (17-4PH)	Alloy C-276
4	Bonnet	SS316 / A479 or A276	Alloy C-276
5	Packing	PTFE (Optional PEEK, Graphite)	
6	Packing Support	Reinforced PTFE	
7	Union Nut	SS316 / A479 or A276	
8	Panel Nut	SS316 / A479 or A276	
9	Gland	SS316 / A479 or A276	Alloy C-276
10	Cap Nut	SS316 / A479 or A276	
11	Packing Bolt	SS316 / A479 or A276	
12	Set Screw	Stainless Steel	
13	Bar Handle	SS316 / A276 (Optional anodized Aluminum)	

* Standard Vee tip, optional Ball and Regulating tip.

Technical Data

Pressure-Temperature Rating with Packing and Body Material

Valve Material	Packing Material	Temperature Range °C (°F)	Pressure Rating @38°C(100°F)	Pressure Rating @Max. Temp.
Stainless Steel 316	PTFE	-54°C to 232°C (-65°F to 450°F)	6000psig (413 bar)	4130psig (284 bar)
	PEEK	-54°C to 315°C (-65°F to 600°F)		3760psig (259 bar)
	Graphite	-54°C to 648°C (-65°F to 1200°F)		1715psig (118 bar)
Alloy C-276	PTFE	-54°C to 232°C (-65°F to 450°F)	6000psig (413 bar)	5710psig (393 bar)
	PEEK	-54°C to 260°C (-65°F to 500°F)		5540psig (381 bar)
	Graphite	-54°C to 648°C (-65°F to 1200°F)		1545psig (106 bar)

* Not applicable over 260°C(500°F) PEEK is not recommended for service with aromatic heat transfer fluids or concentrated sulfuric and nitric acids. Other limitations may apply.

Temperature-Working Pressure

ASME Material Group	Table 2-2.2	N/A
ASME Class Rating	2500	N/A
Material Name	Stainless Steel 316	Alloy C-276
Temperature, °C (°F)	Working Pressure, psig (bar)	
-54°C (-65°F) to 38°C (100°F)	6000 (413)	6000 (413)
93°C (200°F)	5160 (355)	6000 (413)
148°C (300°F)	4660 (321)	6000 (413)
204°C (400°F)	4280 (295)	5820 (401)
232°C (450°F)	4130 (284)	5710 (393)
260°C (500°F)	3980 (274)	5540 (381)
315°C (600°F)	3760 (259)	5040 (347)
426°C (800°F)	3460 (238)	4230 (291)
537°C (1000°F)	3030 (208)	3030 (208)
648°C (1200°F)	1715 (118)	1545 (106)

- Pressure ratings of valves with S-LOK end connections are determined by the tubing material and wall thickness.

- Pressure rating of valve is sometimes limited to the working pressure of pipe ends and the tubing connected.

Flow Data @ 100 F (38°C) for Valves with Regulating Stem tip

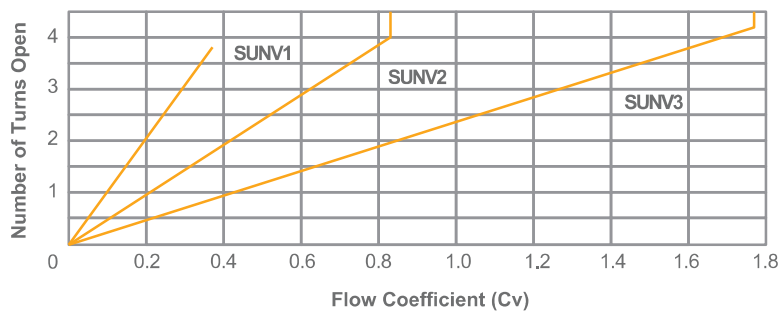

- Valve with standard Vee & Ball tip is designed to be used in a fully open or fully closed position.

Handle

- Stainless steel bar handle is standard all valves. Optionally, anodized black aluminum bar handle is available.
- To order handle for field assembly select desired handle ordering number from the table.

Testing

- Every valve is factory tested with Nitrogen @ 1000psig (69bar)
- Seats have a maximum allowable leak of 0.1 (SSCM).

Ordering Information & Dimensions

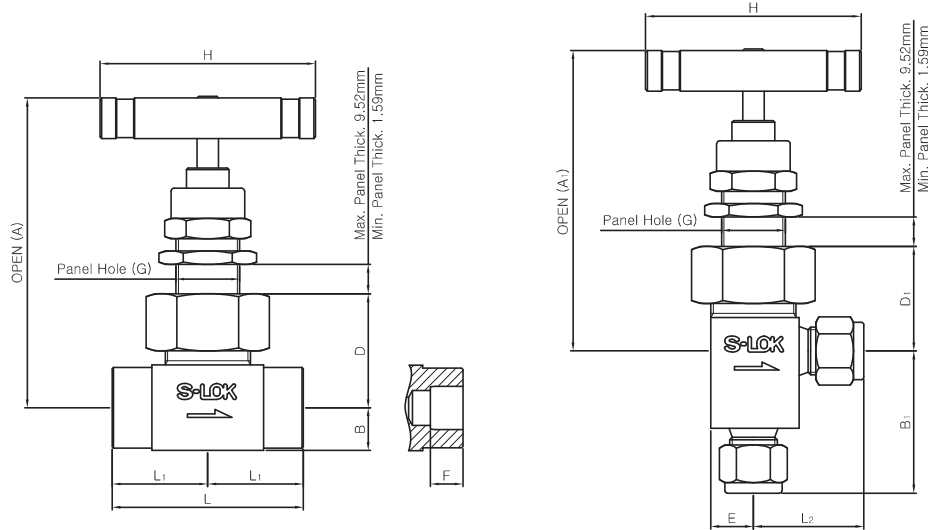

Ordering Number	Orifice (mm)	Cv	End Connections		Dimensions (mm)																
			Inlet	Outlet	A	A ₁	B	B ₁	D	D ₁	E	L	L ₁	L ₂	H	G	F				
SUNV1	4.0	0.35	1/8" Female NPT		77.3	82.0	9.7	25.4	27.7	32.5	9.7	50.8	25.4	22.6	45.0	15.1	-				
			1/4" Female NPT				9.9					52.4	26.2								
			1/4" Male NPT				77.5					9.7	27.7					50.8	25.4	25.4	
			1/4" Male NPT	1/4" Female NPT			82.0					9.9	32.5					52.4	26.2	22.6	
			6mm S-LOK				77.5					9.7	37.6					27.7	61.0	30.5	29.5
			1/4" S-LOK				-					9.7	-					-	-	-	-
			8mm S-LOK				-					-	-					-	-	-	-
			1/4" Tube Socket Weld				77.5					-	30.2					27.7	46.2	23.1	22.4
SUNV2	6.4	0.86	1/4" Female NPT		92.5	97.0	12.7	34.0	37.3	12.7	31.0	57.2	28.6	25.4	64.0	19.8	-				
			3/8" Female NPT									90.7	42.2					71.9	35.8	32.8	
			3/8" S-LOK									90.7	45.7					72.4	36.1	33.0	
			10mm S-LOK									97.0	28.4					77.2	38.6	35.6	
			12mm S-LOK									94.0	31.8					57.2	28.6	25.4	
			1/2" S-LOK									95.5	25.4					-	-	-	
			1/4" Pipe Socket Weld									97.0	28.4					-	-	-	
			3/8" Tube Socket Weld									94.0	31.8					-	-	-	
			1/2" Tube Socket Weld									95.5	25.4					-	-	-	
SUNV3	11.1	2.4	1/2" Female NPT		121.0	126.0	15.7	39.6	46.2	50.8	17.5	79.2	39.6	33.3	88.9	26.2	-				
			3/4" Female NPT		124.0	-	19.8	-	49.5	-	-	82.2	41.1	-							
			1" Female NPT		129.0	-	25.4	-	54.1	-	-	92.0	46.0	-							
		1.9	1/2" Male NPT	1/2" Female NPT	121.0	126.0	15.7	39.6	46.2	50.8	17.5	79.2	39.6	33.3							
			3/4" Male NPT	3/4" Female NPT	124.0	-	19.8	-	49.5	-	-	82.2	41.1	-							
		1" Male NPT		1" Female NPT	129.0	-	25.4	-	54.1	-	-	92.0	46.0	-							
	2.1	12mm S-LOK		121.0	123.0	15.7	52.8	46.2	47.8	17.5	99.6	49.8	42.7								
		1/2" S-LOK																			
		3/4" S-LOK																			
	2.4	1" S-LOK		-	-	-	-	-	-	104.0	52.0	-									
		1/2" Pipe Socket Weld		123.0	126.0	17.5	39.6	47.8	50.8												
	2.2	1/2" Tube Socket Weld		121.0	123.0	15.7	42.9	46.2	47.8	79.2	39.6	33.3									
		3/4" Tube Socket Weld		-	-	-	-	46.2	-	-	-	-	-								
				-	-	-	-	-	-	-	-	-	-								

* Dimensions are for reference only and are subject to change.

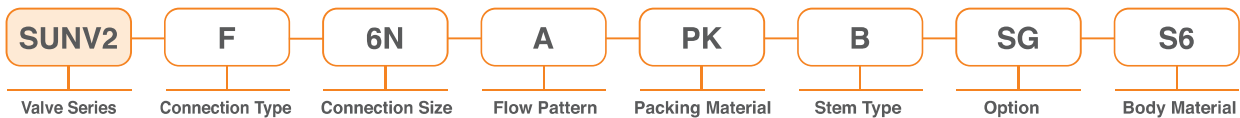

- Nil : Straight
- A : Angle Pattern
- Nil : PTFE
- PK : PEEK
- GF : Graphite
- Nil : Vee
- R : Regulating
- B : Ball
- Nil : Standard
- SG : Sour Gas Service
- S6 : 316 Stainless Steel
- C276 : Alloy C-276

SQNV Series Square Bar Stock Needle Valves

Features

- Pressure rating up to 6000psig (413bar) at 21°C (70°F).
- Temperature rating from -28°C (-20°F) to 204°C (400°F) with standard FKM O-ring.
- Compact design & low operating torque.
- Available panel mounting.
- Non-rotating stem tip provide positive seal and prevents galling.
- Sealed below the stem threads to prevents lubricant washout.
- Safety back seating seals in fully open position.
- Bonnet lock pin prevents accidental valve disassembly.



Material of Construction

No	Component	Material	
		Stainless Steel	Alloy 400
1	Body	SS316 / A479 or A276	Alloy 400 / B164
2	Bonnet		
3	Stem		
4	Stem Tip	SS630 / A564	Alloy R-405 / B164
5	O-ring	FKM	
6	Backup-ring	PTFE	
7	Dust Cap	NBR	
8	Bar Handle	SS316 / A276	
9	Set Screw	Stainless Steel	

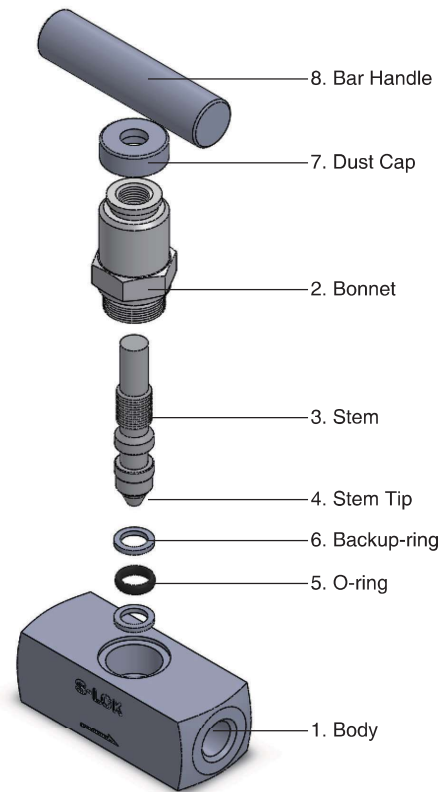

Pressure - Temperature Ratings

ASME Material Group	Table 2-2.2	Table 2-3.4
ASME Class Rating	2500	
Material Name	Stainless Steel 316	Alloy 400
Temperature, °C (°F)	Working Pressure, psig (bar)	
-28°C (-20°F) to 38°C (100°F)	6000 (413)	5000 (344)
93°C (200°F)	5160 (355)	4380 (301)
148°C (300°F)	4660 (321)	4080 (281)
204°C (400°F)	4280 (295)	3940 (271)

O-ring Material	Temperature, °C (°F)
FKM	-28°C ~ 204°C (-20°F ~ 400°F)
NBR	-20°C ~ 105°C (-4°F ~ 221°F)
EPDM	-28°C ~ 148°C (-20°F ~ 300°F)

- Pressure ratings of valves with S-LOK end connections are determined by the tubing material and wall thickness.

Flow Coefficient (Cv) with Number of Handle Turns Testing

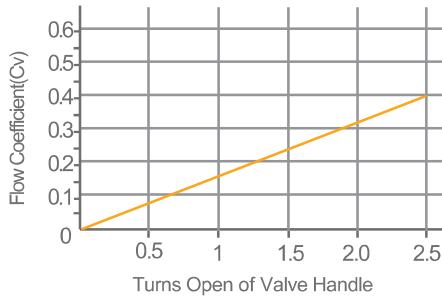

- Every valve is factory tested with Nitrogen @ 1000psig (69bar)
- Seats have a maximum allowable leak of 0.1 (SSCM).
- Hydrostatic shell test is performed optional with water at 1.5 times the working pressure.

Sour Gas Service

- Sour gas service provided to accordance with NACE MR0175.

Ordering Information & Dimensions

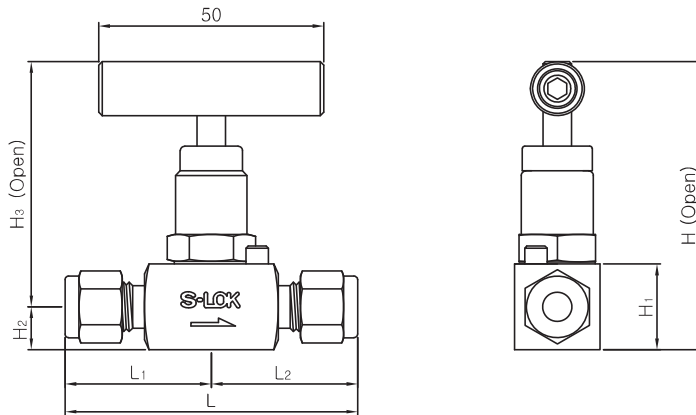

Ordering Number	Orifice (mm)	End Connections		Dimensions (mm)						
		Inlet	Outlet	L	L ₁	L ₂	H	H ₁	H ₂	H ₃
F-2N	4.8	1/8" Female NPT		57.0	28.5		64.0	19.0	9.5	9.5
F-4N		1/4" Female NPT								
MF-2N		1/8" Male NPT	1/8" Female NPT							
MF-4N		1/4" Male NPT	1/4" Female NPT							
S-2T		1/8" S-LOK		63.6	31.8		70.5	25.4	12.7	12.7
S-6M		6mm S-LOK		65.0	32.5					
S-4T		1/4" S-LOK		68.0	34.0					
S-6T		3/8" S-LOK								
S-12M		12mm S-LOK		73.2	36.6		73.5	28.5	14.3	14.3
S-8T		1/2" S-LOK		62.0	31.0					
F-6N		3/8" Female NPT								
MF-6N		3/8" Male NPT	3/8" Female NPT	70.0	35.0					
F-8N		1/2" Female NPT		74.0	39.0	35.0				
MF-8N		1/2" Male NPT	1/2" Female NPT							

* Dimensions are for reference only and are subject to change.

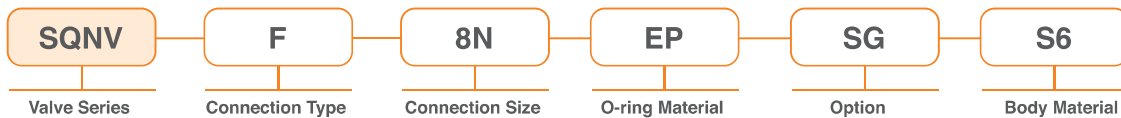

- VT : FKM
- NBR : NBR
- EP : EPDM
- Nil : Standard
- SG : Sour Gas Service
- PN : Panel Mounting
- S6 : 316 Stainless Steel
- A400 : Alloy 400

SDNV30 Series Non-rotating Stem Needle Valves

Features

- Pressure rating up to 3000psig (206bar) at 21°C (70°F).
- Temperature rating from -28°C (-20°F) to 93°C (204°F) with standard FKM O-ring and PCTFE stem tip.
- One-piece forge body is available in straight and angle flow patterns.
- Non-rotating stem tip provide positive seal and repetitive shutoff.
- Safety back seating seals in fully open position.
- Thread of handle isolated from system fluid.
- Handle to prevent external contaminants from entering the valve.
- Available Sour Gas service per NACE MR0175.



Materials of Construction

No	Component	Material		
		Stainless Steel	Brass	Alloy 400
1	Body	SS316 / A182	Brass / B124	Alloy 400 / B564
2	Stem Tip	PCTFE (Optional PEEK)		
3	Stem	SS316 / A479 or A276		Alloy R-405 / B164
4	Washer	SS316 / A276	Aluminum	
5	O-ring	FKM (Optional NBR, EPDM)		
6	Backup-ring	PTFE		
7	Packing Bolt	SS316 / A276	Brass / B16	Alloy R-405 / B164
8	Spool	Aluminum		
9	Retaining Ring	Stainless Steel		
10	Handle	Aluminum (Black anodized)		

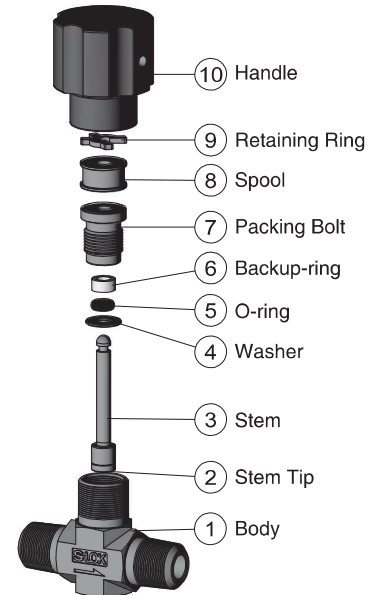

Temperature-Working Pressure

ASME Material Group	Table 2-2.2	N/A	Table 2-3.4
ASME Class Rating	2500	N/A	1500
Material Name	Stainless Steel 316	Brass	Alloy 400
Temperature, °C (°F)	Working Pressure, psig (bar)		
-28°C (-20°F) to 38°C (100°F)	3000 (206)	3000 (206)	3000 (206)
93°C (200°F)	2580 (177)	2350 (161)	2630 (181)
148°C (300°F)	2330 (160)	2050 (141)	2450 (168)
204°C (400°F)	2140 (147)	390 (26)	2365 (163)

- Pressure ratings of valves with S-LOK end connections are determined by the tubing material and wall thickness.

O-ring Material	Temperature, °C (°F)
FKM	-28°C ~ 204°C (-20°F ~ 400°F)
NBR	-20°C ~ 105°C (-4°F ~ 221°F)
EPDM	-28°C ~ 148°C (-20°F ~ 300°F)
Stem Tip Material	Temperature, °C (°F)
PCTFE	-28°C ~ 93°C (-20°F ~ 200°F)
PEEK	-28°C ~ 232°C (-20°F ~ 450°F)

Flow Coefficient (Cv) with Number of Handle Turns

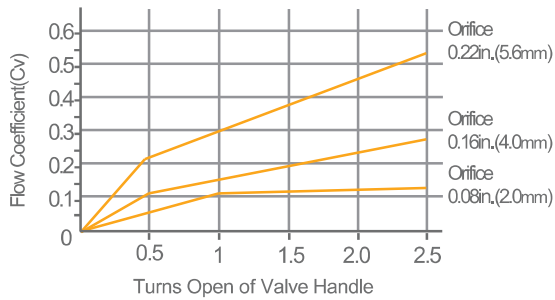

Testing

- Every valve is factory tested with Nitrogen @ 1000psig (69bar)
- Seats have a maximum allowable leak of 0.1 (SSCM).

Sour Gas Service

- Sour gas service provided to accordance with NACE MR0175.

Ordering Information & Dimensions

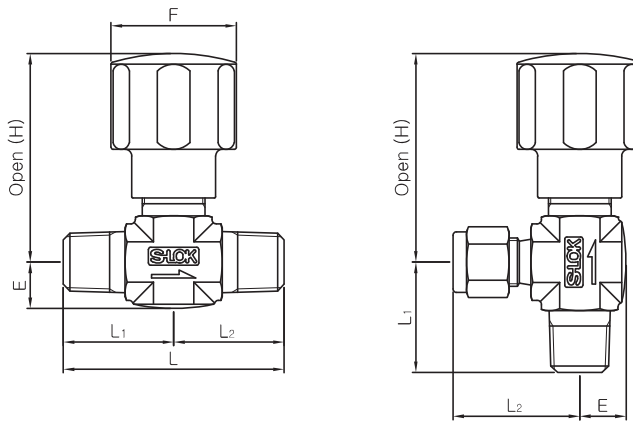

Ordering Number	Orifice (mm)	Cv	End Connections		Dimensions (mm)						
			Inlet	Outlet	L	L ₁	L ₂	E	F	H	
SDNV1	MF-2N	2.4	0.12	1/8" Male NPT	1/8" Female NPT	45.4	21.4	24.0	9.7	28.4	47.2
	MS-2N4T			1/8" Male NPT	1/4" S-LOK	50.1	21.4	28.7			
	S-2T	1/8" S-LOK		55.8	27.9						
	M-4N	1/4" Male NPT		50.0	25.0						
	MS-4N4T	1/4" Male NPT	1/4" S-LOK	53.7	25.0	28.7					
	MS-4N6M	1/4" Male NPT	6mm S-LOK								
	S-6M	6mm S-LOK		57.4	28.7						
	S-4T	1/4" S-LOK									
SDNV2	F-4N	5.6	0.53	1/4" Female NPT		54.0	27.0		14.2	31.8	51.3
	M-4N			1/4" Male NPT		57.4	28.7				
	M-6N			3/8" Male NPT							
	MF-4N			1/4" Male NPT	1/4" Female NPT	55.6	28.4	26.9			
	MS-4N6T			1/4" Male NPT	3/8" S-LOK	60.7	28.7	32.0			
	MF-8N4N			1/2" Male NPT	1/4" Female NPT	63.5	31.8	31.8			
	S-6T			3/8" S-LOK		65.6	32.8				

* Dimensions are for reference only and are subject to change.

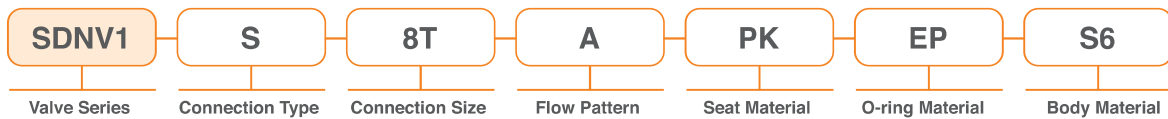

- Nil : Straight
- A : Angle Pattern
- Nil : PCTFE
- PK : PEEK
- Nil : FKM
- NBR : NBR
- EP : EPDM
- S6 : 316 Stainless Steel
- BS : Brass
- A400 : Alloy 400

STV50 Series 3-Way Test Cock Valves

Features

- Pressure rating up to 5000psig (344bar) at 21 °C (70 °F).
- Temperature rating from -54 °C (-65 °F) to 232 °C (450 °F) with standard PTFE packing and up to 315 °C (600 °F) with PEEK packing.
- One-piece forged 3-way test cock valve.
- Added one more port to needle valve for testing.
- Variety of end connections include reliable tube fittings, male/female NPT & ISO threads.
- Available Sour Gas service per NACE MR0175.



Materials of Construction

No	Component	Material	
		Stainless Steel	Brass
1	Body	SS316 / A182	Brass / B124
2	Stem	SS316 / A479 or A276	
3	Packing Ring	SS316 / A479 or A276	Brass / B16
4	Packing	PTFE (Optional PEEK)	
5	Gland	SS316 / A276	Brass / B16
6	Packing Nut	SS316 / A276	Brass / B16
7	Lock Nut	Stainless Steel	
8	Round Handle	Stainless Steel	
9	Name Plate	Aluminum	
10	Hex Nut	Stainless Steel	
11	ED-ring	NBR (Optional FKM)	
12	Plug	SS316 / A479 or A276	Brass / B16

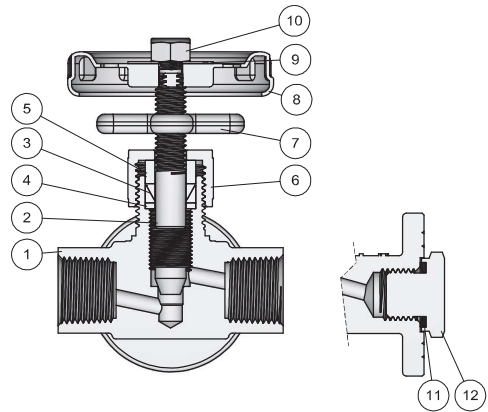

Technical Data

Pressure-Temperature Rating with Packing and Body Material

Valve Material	Stem	PTFE Packing (Standard)		PEEK Packing (Optional)	
		Temperature Range °C (°F)	Pressure Rating @38 °C(100 °F)	Temperature Range °C (°F)	Pressure Rating @Max. Temp.
Stainless Steel 316	Vee Stem (Metal Seat)	-54 °C to 232 °C (-65 °F to 450 °F)	5000psig (344 bar)	-54 °C to 315 °C (-65 °F to 600 °F)	3130psig (215 bar)
Brass	Vee Stem (Metal Seat)	-54 °C to 204 °C (-65 °F to 400 °F)	3000psig (206 bar)	-54 °C to 204 °C (-65 °F to 400 °F)	390psig (26 bar)

Testing

- Every valve is factory tested with Nitrogen @ 1000psig (69bar) for leak at the seats have a maximum allowable leak of 0.1 (SSCM).

Ordering Information & Dimensions

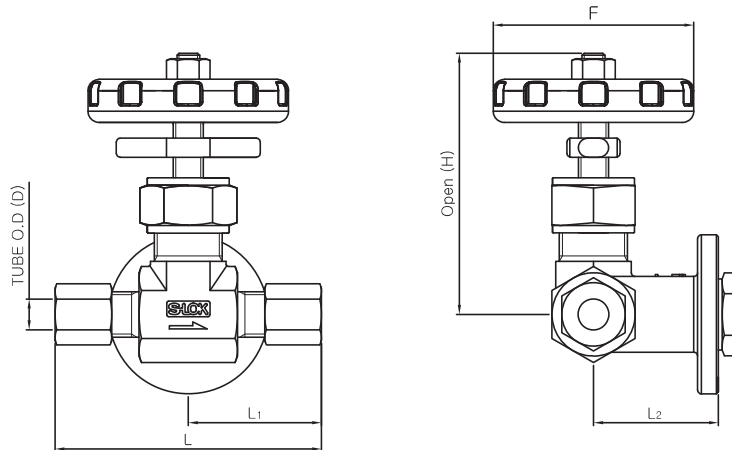

Ordering Number	Orifice (mm)	End Connections		Dimensions (mm)						
		Inlet	Outlet	D	L	L ₁	L ₂	F	H	
STV	F-02R	4.0	1/8" Female ISO Thread		-	50.0	25.0	33.0	53.0	69.0
	F-03R		3/8" Female ISO Thread		-	64.0	32.0			
	M-02R		1/8" Male ISO Thread		-	56.0	28.0			
	M-03R		3/8" Male ISO Thread		-	58.0	29.0			
	B-06M		6mm JIS 2351 Bite		6.0	65.6	32.8			
	B-08M		8mm JIS 2351 Bite		8.0	71.6	35.8			
	B-10M		10mm JIS 2351 Bite		10.0	73.6	36.8			
	B-12M		12mm JIS 2351 Bite		12.0	75.6	37.8			
	S-2T		1/8" S-LOK		3.17	58.4	29.2			
	S-4T		1/4" S-LOK		6.35	63.4	31.7			
	S-6T		3/8" S-LOK		9.52	66.4	33.2			
	S-8T		1/2" S-LOK		12.7	72.0	36.0			
	S-6M		6mm S-LOK		6.0	63.4	31.7			
	S-8M		8mm S-LOK		8.0	65.2	32.6			
	S-10M		10mm S-LOK		10.0	67.0	33.5			
	S-12M		12mm S-LOK		12.0	72.0	36.0			

* Dimensions are for reference only and are subject to change.

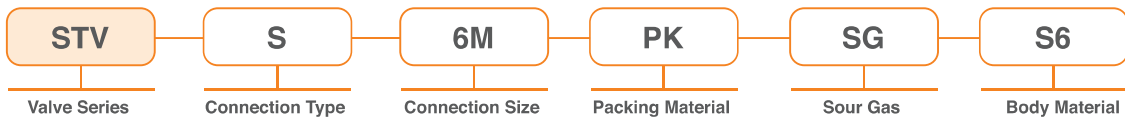

- Nil : PTFE
- Nil : Standard
- S6 : 316 Stainless Steel
- PK : PEEK
- SG : Sour Gas Service
- BS : Brass

STGV Series Toggle Valves

Features

- Working Pressure up to 300 psi (20.6 bar)
- Temperatures up to 200°F (93°C)
- Compact, rugged design
- Panel mountable
- Soft seat shutoff
- Quick opening and closing
- O-ring stem seals do not need adjustment
- Stainless steel and brass construction
- Straight and angle patterns available
- Every valve is 100% factory tested



Testing

- Every valve is factory tested for bubble-tight leakage at both seat and stem packing with nitrogen at 300psi (13.7bar).

Operation

- Lift the handle to fully open the valve.
- The handle stops firmly in the open position.
- Lower the handle, shutoff the valve by spring return.
- The soft seat provides positive seal.

Pressure – Temperature Ratings

Valve Series	Orifice mm (inch)	Working Pressure psi (bar)	Temperature °F (°C)
STGV1	2.0 (0.080)	300 (20.6)	-20 to 200 (-28 to 93)
	3.2 (0.125)		
STGV2	6.4 (0.250)	200 (13.7)	

Materials of Construction

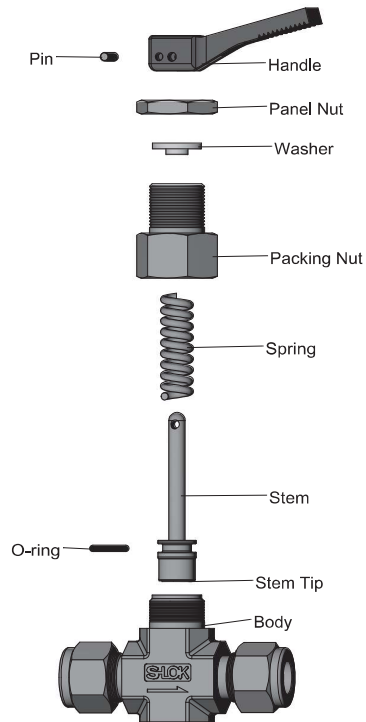

Component	Material	
	SS 316	Brass
Body	SS 316 / A182	Brass / B283
Packing Nut	SS 316 / A276	Brass / B16
Stem	SS 316 / A276	
Spring	SS 304	
Stem Tip	PTFE	
Washer	Nylon	
Handle	Nylon	
Panel Nut	SS 316 / A276	Brass / B16
O-ring	FKM	
Pin	Stainless Steel	

Table of Dimension

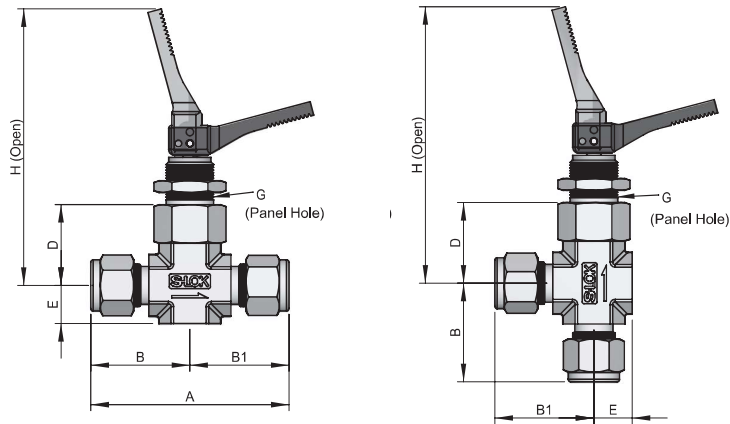

Ordering Number	End Connections		Cv	Orifice mm (inch)	Dimensions, mm (inch)							
	Inlet / Outlet	Size			A	B	B1	D	E	G	H	
STGV1	S-2T	S-LOK	1/8"	0.11	2.0 (0.08)	49.8 (1.96)	24.9 (0.98)	23.4 (0.92)	7.9 (0.31)	13.5 (0.53)	73 (2.87)	
	S-4T	S-LOK	1/4"	0.2	3.2 (0.125)	57.4 (2.26)	28.7 (1.13)	23.4 (0.92)	7.9 (0.31)	13.5 (0.53)	73 (2.87)	
	S-3M	S-LOK	3mm	0.11	2.0 (0.08)	49.8 (1.96)	24.8 (0.98)	23.4 (0.92)	7.9 (0.31)	13.5 (0.53)	73 (2.87)	
	S-6M	S-LOK	6mm	0.2	3.2 (0.125)	57.4 (2.26)	28.7 (1.13)	23.4 (0.92)	7.9 (0.31)	13.5 (0.53)	73 (2.87)	
	S-8M	S-LOK	8mm	0.2	3.2 (0.125)	56.4 (2.22)	28.2 (1.11)	23.4 (0.92)	7.9 (0.31)	13.5 (0.53)	73 (2.87)	
	F-2N	Female NPT	1/8"	0.2	3.2 (0.125)	41.4 (1.63)	20.7 (0.81)	23.4 (0.92)	7.9 (0.31)	13.5 (0.53)	73 (2.87)	
	M-2N	Male NPT	1/8"	0.2	3.2 (0.125)	38.0 (1.5)	19.0 (0.75)	23.4 (0.92)	7.9 (0.31)	13.5 (0.53)	73 (2.87)	
	M-4N	Male NPT	1/4"	0.2	3.2 (0.125)	46.0 (1.81)	23.0 (0.91)	23.4 (0.92)	7.9 (0.31)	13.5 (0.53)	73 (2.87)	
	MS-2N2T	Male NPT / S-LOK	1/8"	0.11	2.0 (0.08)	43.9 (1.73)	19.0 (0.75)	24.9 (0.98)	23.4 (0.92)	7.9 (0.31)	13.5 (0.53)	73 (2.87)
	MS-4N4T	Male NPT / S-LOK	1/4"	0.2	3.2 (0.125)	51.7 (2.04)	23.0 (0.91)	28.7 (1.13)	23.4 (0.92)	7.9 (0.31)	13.5 (0.53)	73 (2.87)
	MF-2N	Male / Female NPT	1/8"	0.2	3.2 (0.125)	41.4 (1.63)	20.7 (0.81)	23.4 (0.92)	7.9 (0.31)	13.5 (0.53)	73 (2.87)	
STGV2	S-6T	S-LOK	3/8"	0.7	6.4 (0.25)	65.5 (2.58)	32.8 (1.29)	26.9 (1.06)	12.7 (0.50)	16.8 (0.66)	90.6 (3.56)	
	S-8T	S-LOK	1/2"	0.7	6.4 (0.25)	71.1 (2.8)	35.6 (1.4)	26.9 (1.06)	12.7 (0.50)	16.8 (0.66)	90.6 (3.56)	
	S-10M	S-LOK	10mm	0.7	6.4 (0.25)	69.1 (2.72)	34.5 (1.36)	26.9 (1.06)	12.7 (0.50)	16.8 (0.66)	90.6 (3.56)	
	S-12M	S-LOK	12mm	0.7	6.4 (0.25)	74.4 (2.93)	37.2 (1.46)	26.9 (1.06)	12.7 (0.50)	16.8 (0.66)	90.6 (3.56)	
	F-4N	Female NPT	1/4"	0.7	6.4 (0.25)	53.8 (2.12)	26.9 (1.06)	26.9 (1.06)	12.7 (0.50)	16.8 (0.66)	90.6 (3.56)	
	M-6N	Male NPT	3/8"	0.7	6.4 (0.25)	57.2 (2.25)	28.6 (1.12)	26.9 (1.06)	12.7 (0.50)	16.8 (0.66)	90.6 (3.56)	

Dimensions are for reference only and are subject to change. Dimensions shown with S-LOK nuts finger-tight position.

Ordering Information

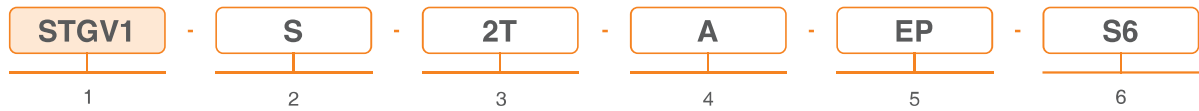

1. Valve Series

- STGV1
- STGV2

2. End Connection

- **S** : S-LOK
- **M** : Male Pipe Thread
- **F** : Female Pipe Thread
- **MS** : S-LOK x Male Pipe Thread
- **MF** : Male x Female Pipe Thread

3. Size Designator

- **2T** : 1/8"
- **4T** : 1/4"
- **6T** : 3/8"
- **8T** : 1/2"
- **3M** : 3mm
- **6M** : 6mm
- **8M** : 8mm
- **10M** : 10mm
- **12M** : 12mm
- **2N** : 1/8" NPT
- **4N** : 1/4" NPT
- **6N** : 3/8" NPT

4. Flow Pattern

- **Nil** : Straight
- **A** : Angle

5. O-ring Material

- **Nil** : FKM
- **NBR** : NBR
- **EP** : EPDM

6. Body Material

- **S6** : 316 Stainless Steel
- **BS** : Brass

SMTV Series Low Pressure Metering Valves

✦ Features

- Forged body SS316 or brass material.
- Straight and angle patterns.
- Variety of end connections include S-LOK, NPT & ISO threads Male/Female.
- Variety of handle options : knurled, round, vernier, slotted, and adjustable torque handles.
- Flow setting lock system : knurled and slotted handles.
- Handle stop design : Prevent damage to stem and orifice.
- Panel mounting is standard for all valves.
- Tapered stem tip : Provide a wide flow range with ultrafine metering control.



✦ Material of Construction

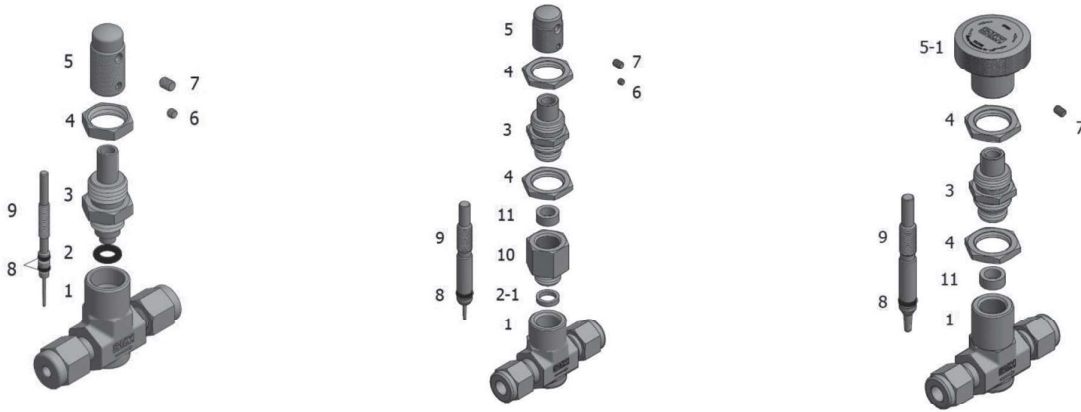

Item	Component	Material	
		Stainless Steel	Brass
1	Body	SS316 / A182	Brass / B124
2	Body O-ring	FKM	NBR
2-1	Body Seal	Stainless Steel	
3	Bonnet	SS316 / A479 or A276	* Brass / B16
4	Lock Nut	SS316 / A479 or A276	* Brass / B16
5	Handle	Stainless Steel	* Brass / B16
5-1	Round Handle	Aluminum 6061	
6	Lock Screw	Stainless Steel	
7	Set Screw	Stainless Steel	
8	Stem O-ring	FKM	NBR
9	Stem	SS316 / A479 or A276	
10	Body Extension	SS316 / A479 or A276	* Brass / B16
11	Stem Guide Ring	PTFE	

* Chrome Plated

Technical Data

Pressure and Temperature Ratings

Valve Series	Temperature Ratings with O-ring Material			Pressure Rating @38°C(100°F)	Stem Taper	Flow Shut off
	FKM (Viton)	NBR	FFKM (Kalrez)			
SMTV1	-23°C to 204°C (-10°F to 400°F)	-23°C to 148°C (-10°F to 300°F)	-17°C to 148°C (0°F to 300°F)	2000psig (137 bar)	1°	No
SMTV2				1000psig (68.9 bar)	3°	No
SMTV3				1000psig (68.9 bar)	6°	Yes

Flow Data with Number of Handle Turns

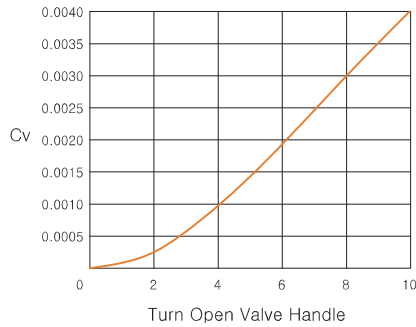

SMTV1 Series

Pressure Drop@ Atmosphere psi (bar)	Air Flow Std. ft ³ /min. (Std. L/min.)	Water Flow U.S. gal/min. (L/min.)
10 (0.68)	0.04 (1.1)	0.01 (0.03)
50 (3.4)	0.1 (2.8)	0.02 (0.07)
100 (6.8)	0.2 (5.6)	0.04 (0.15)

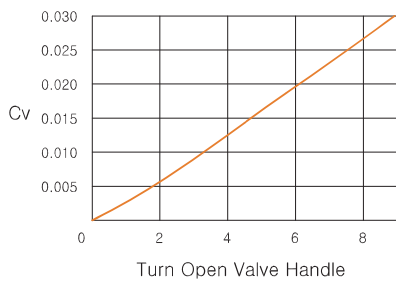

SMTV2 Series

Pressure Drop@ Atmosphere psi (bar)	Air Flow Std. ft ³ /min. (Std. L/min.)	Water Flow U.S. gal/min. (L/min.)
10 (0.68)	0.33 (9.3)	0.09 (0.34)
50 (3.4)	0.9 (25.4)	0.21 (0.79)
100 (6.8)	1.5 (42.4)	0. (1.1)

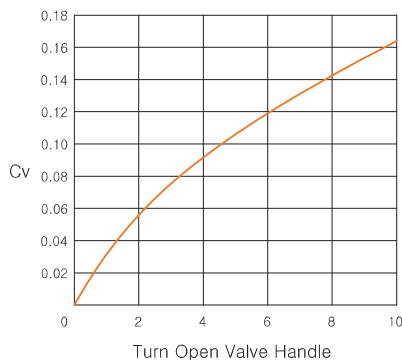

SMTV3 Series

Pressure Drop@ Atmosphere psi (bar)	Air Flow Std. ft ³ /min. (Std. L/min.)	Water Flow U.S. gal/min. (L/min.)
10 (0.68)	2.0 (56.6)	0.51 (1.9)
50 (3.4)	6.4 (181.0)	1.2 (4.5)
100 (6.8)	11.4 (323.0)	1.7 (6.4)

Dimensions

Straight Pattern

Ordering Number	Orifice (mm)	Cv	End Connections		Dimensions (mm)			
			Inlet	Outlet	L	A	D	H
SMTV1	S-1T	0.81	0.004	1/16" S-LOK	39.6	58.0	23.9	9.6
	S-2T			48.2				
	S-3M			3mm S-LOK				
	S-4T			1/4" S-LOK				
	S-6M			6mm S-LOK				
SMTV2	S-2T	1.42	0.03	1/8" S-LOK	51.3	72.0	42.2	12.7
	S-3M			3mm S-LOK				
	S-4T			1/4" S-LOK				
	S-6M			6mm S-LOK				
	M-2N			1/8" Male NPT				
	M-4N			1/4" Male NPT				
	F-2N			1/8" Female NPT				
SMTV3	S-4T	3.25	0.16	1/4" S-LOK	59.4	73.0	34.4	28.7
	S-6M			6mm S-LOK				
	S-6T			3/8" S-LOK				
	M-4N			1/4" Male NPT				

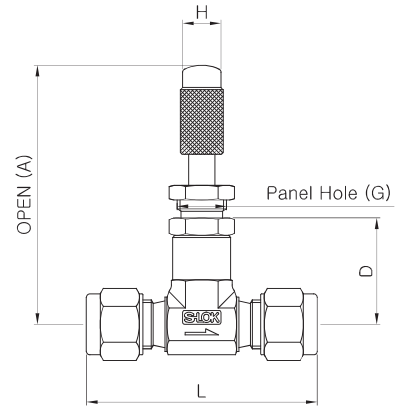

Series	Panel Hole (G)	Panel MaxThickness
SMTV1	11.4	4.1
SMTV2	14.7	3.3
SMTV3	14.7	3.3

Angle Pattern

Ordering Number	Orifice (mm)	Cv	End Connections		Dimensions (mm)				
			Inlet	Outlet	L1	L2	A	D	H
SMTV1	S-1T	0.81	0.004	1/16" S-LOK	20.6	22.4	80.4	23.9	9.6
	S-2T			24.1	82.1				
	S-3M			24.9	25.1	83.9			
	S-4T			25.9	83.1				
SMTV2	S-2T	1.42	0.03	1/8" S-LOK	25.6	84.6	29.2	12.7	
	S-3M			3mm S-LOK					
	S-4T			1/4" S-LOK					
	S-6M			6mm S-LOK					
	M-2N			1/8" Male NPT					
	M-4N			1/4" Male NPT					
	F-2N			1/8" Female NPT					
SMTV3	S-4T	3.25	0.16	1/4" S-LOK	28.7	97.1	28.8	28.7	
	S-6M			6mm S-LOK					

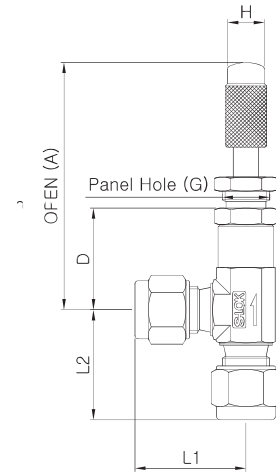

Series	Panel Hole (G)	Panel MaxThickness
SMTV1	11.4	4.1
SMTV2	14.7	3.3
SMTV3	14.7	3.3

Ordering Information

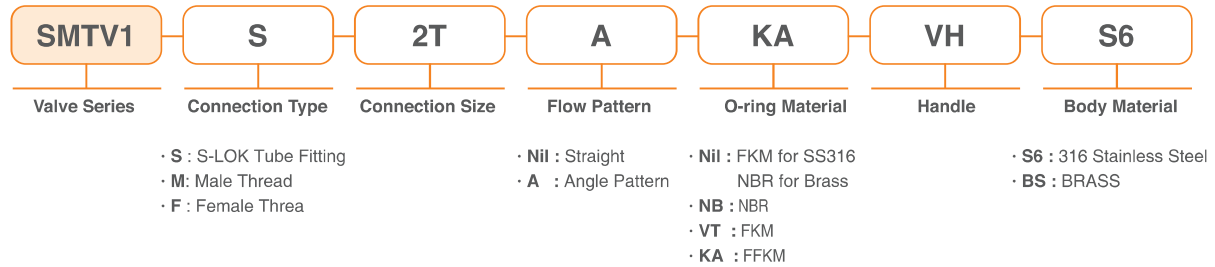

Handle Option

- **Nil** : SMTV1, 2 Series Standard for Locking Screw Handle
SMTV3 Series Standard for Round Handle
- **SH** : SMTV1, 2 Series
- **AH** : SMTV1 Series
- **VH** : SMTV1, 2, 3 Series



SMTV1, 2 Standard
Locking Screw
Handle



SMTV3 Standard
Round Handle



SH
Slotted Handle



AH
Adjustable Torque
Handle



VH
Vernier Handle

SMTVH Series High Pressure Metering Valves

⚡ Features

- SS316 bar stock body with straight and angle patterns.
- Variety of end connections include S-LOK, NPT & ISO threads Male/Female.
- Phenolic knob round handle.
- Panel mounting is standard for all valves.
- Union nut-prevents accidental disassembly of the valve in its service.
- Metal to metal low shut off.
- 2° Tapered stem tip : Provide a wide flow range with ultrafine metering control.



⚡ Material of Construction

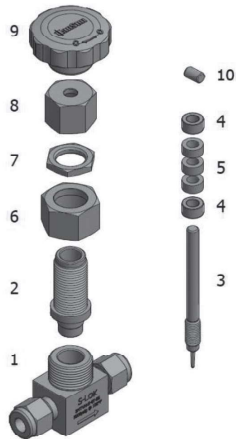

Item	Component	Material
1	Body	SS316 / A479 or A276
2	Bonnet	SS316 / A479 or A276
3	Stem	SS630 / A564 (17-4PH)
4	Gland	SS316 / A479 or A276
5	Packing	PTFE
6	Union Nut	SS316 / A479 or A276
7	Panel Nut	SS316 / A479 or A276
8	Packing Nut	SS316 / A479 or A276
9	Handle	Nylon with Brass Insert
10	Set Screw	Stainless Steel

⚡ Technical Data

Pressure and Temperature Ratings

ASME Material Group	Table 2-2.2
ASME Class Rating	2080
Temperature @ Pressure	psig (bar)
-54°C (-65°F) ~ 38°C (100°F)	5000 (344)
93°C (200°F)	4295 (295)
148°C (300°F)	3875 (266)
204°C (400°F)	3560 (245)
232°C (450°F)	3435 (236)
260°C (500°F)	3310 (228)
315°C (600°F)	3130 (215)
343°C (650°F)	3080 (212)
371°C (700°F)	3000 (206)
398°C (750°F)	2930 (201)
426°C (800°F)	2880 (198)
454°C (850°F)	2815 (193)

Flow Data with Number of Handle Turns

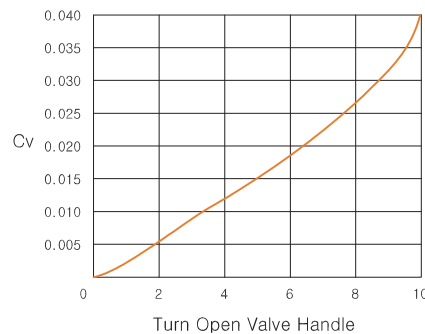

Pressure Drop @ Atmosphere psi (bar)	Air Flow Std. ft ³ /min. (Std. L/min.)	Water Flow U.S. gal/min. (L/min.)
10 (0.68)	0.04 (1.1)	0.01 (0.03)
50 (3.4)	0.1 (2.8)	0.02 (0.07)
100 (6.8)	0.2 (5.6)	0.04 (0.15)

Dimension

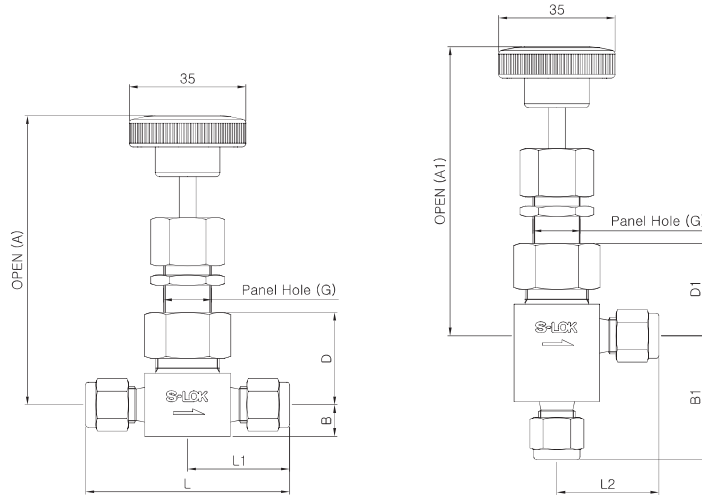

Panel Hole (G)	Panel Max Thickness
15.0	9.6

Ordering Number	Orifice (mm)	Cv	End Connections		Dimensions (mm)										
			Inlet	Outlet	L	L1	L2	A	A1	B	B1	D	D1		
SMTVH	S-4T	1.6	0.04	1/4" S-LOK		60.6	30.3	29.5	87.8	87.8	9.6	37.6	28.1	28.1	
	S-6M			6mm S-LOK											23.1
	F-2N			1/8" Female NPT		52.4	26.2	23.1				92.9			
	F-4N			1/4" Female NPT											52.4

Testing

- Every valve is factory tested for bubble-tight leakage at both seat and stem packing with nitrogen at 1000psi (69bar).

Ordering Information

SMTVH	-	S	-	2T	-	A	-	GF	-	S6
Valve Series Designator		End Connection Designator		Inlet-Outlet Size Designator		Flow Pattern Designator		Packing Material Designator		Body Material Designator
		. S : S-LOK Tube Fitting . M: Male Thread . F : Female Thread				. Nil : Straight . A : Angle		. Nil : PTFE . GF : Graphite		. S6 : Stainless Steel 316 . BS : Brass

S-LOK®